

Welcome to the world of valve technology

This is the world of solenoid valves, with and without explosion protection, of external medium-controlled valves and motorised valves.

With a range that includes more than 3000 special valves and an extensive standard program, we supply valve solutions for nearly all applications.

In the standard valve field we have a selection of four control types and over 900 valve combinations.

Looking for a new coil or a service set? Enjoy the top quality service provided by our spare parts depot. Our delivery range is also complemented by a choice selection of accessories.

Or do you need the support of our technical specialists?

Just give us a call!



We hope you enjoy browsing through the GSR world of valves

Your GSR Team

- Errors excepted, subject to change.
- Original products may vary from the product photographs due to deviating materials etc.

GSR - your partner for valve technology



Our core competence concentrates on the rapid development of special customised solutions in all areas of valve technology. Over the past 30 years, the GSR engineers have developed special valves that have been installed reliably in nearly all technologies under diverse conditions.

As all the most important system components are produced on state-of-the-art machines in our own production facilities, we are able to manufacture top quality customised products as well as larger series.

Our fully automatic high-rack warehouse ensures optimised, quicker processes allowing us to satisfy our customers' demands today and also in the future.

All business processes comply with DIN EN ISO 9001 and are continuously controlled and improved by the GSR quality assurance and our technical development team.

Certifications:

- DIN EN ISO 9001
- EC examination certificate in accordance with 94/9/EG (ATEX)
- EC examination certificate in accordance with EC gas equipment directive 90/396 (DIN EN 161)
- DVGW approvals
- Hungarian approvals for magnetic coils in accordance with BKI
- 3-A approval in accordance with sanitary standard 53-02
- Inspected sample valves for natural-gas run cars in accordance with ECE R110
- Module H-approval (approved manufacturer) in accordance with pressure equipment directive 97/23/EG
- GOST-R certificate
- Russian hygiene certificate
- Germanischer Lloyd



GSR Ventiltechnik GmbH & Co. KG
Im Meisenfeld 1 • D-32602 Vlotho
P.O. Box 2060 • D-32595 Vlotho
Germany
Telephone +49 5228 779-0
Fax +49 5228 779-190
info@ventiltechnik.de
www.ventiltechnik.de

Pilot operated solenoid valves

Pilot operated solenoid valves are distinguished by their simple, sturdy design. The sealing element is a diaphragm for application pressures of up to 20 bar or sturdy piston pressures of 25, 40, 100 up to 150 bar.



Application fields

- Filling systems
- Irrigation systems
- Fountain equipment
- Sanitary equipment
- Water treatment
- Pneumatics
- Mixing systems
- Pipelines
- Drinking water supply
- and many other applications in the general machine and equipment construction field

Body and sealing materials

- Body made of brass, stainless steel, GG-25, GS-C25
- Seals made of NBR, EPDM, FKM, PTFE
- Peek for high temperatures and pressures



Type 25



Type 28



Type 40



Type 44*



Type 46

Type	Design	Nominal size	Connection		Function	Pressure range min/max	Medium	Medium temp.		Elect. Connection
			Threaded	Flanged				norm. °C	max. °C	
25	2/2-Way valve with piston seal	DN13 - DN250		PN 16/40	NC/NO	1-40 bar	gaseous Viscosity up to 22 mm ² /s	-10/+80	-40/+200	12*, 24*, 48*, 110, 120*, 230, 240*V DC/AC EEx (e) m II T4 Encapsulation „m” Cable or terminal connection Voltage tolerance +5/-10% EEx ia II c intrinsically safe
28	2/2-Way valve with diaphragm seal	DN15 - DN50		PN 16/40	NC/NO	0,5-16 bar		-10/+80	-20/+130	
40	2/2-Way valve with diaphragm seal	DN13 - DN75	G ¹ / ₄ -G3		NC/NO	0,3-20 bar or 0,3-16 bar		-10/+80	-20/+130	
44*	2/2-Way valve with diaphragm seal or piston seal	DN13	G ¹ / ₈ -G ¹ / ₂		NC/NO	0,5-16 bar		-10/+80		
46	2/2-Way valve with piston seal	DN8 - DN40	G ¹ / ₄ -G ⁶ / ₄		NC/NO	1-150 bar		-10/+80	-40/+200	
50	2/2-Way valve with piston seal	DN13 - DN50	G ¹ / ₄ -G2		NC/NO	1-40 bar		-10/+80	-40/+200	
51	2/2-Way valve with piston seal	DN13 - DN25	G ¹ / ₄ -G1		NC/NO	0,5-40 bar		-10/+80		
74	3/2-Way valve with piston seal	DN11 - DN50	G ¹ / ₄ -G2		NC/NO	2-12 bar		-10/+80	-20/+130	
2/529	2/2-Way valve with piston seal	DN6 - DN50	G ¹ / ₈ -G2		NC/NO	1-450 bar		-20/+80	-40/+130	

* also available as force pilot operated and pressure controlled valve



Type 50

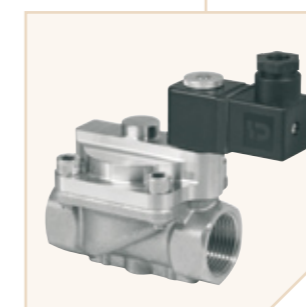

Type 51

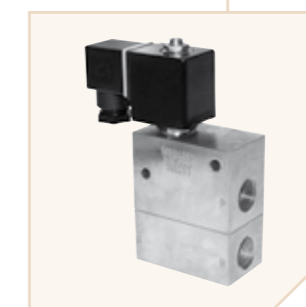

Type 74



Type 2/529

Benefits of this control type

It is possible for small coils to control high pressures with large nominal sizes. The installation position of these valves can vary as required up to DN 50. Service-friendly thanks to the fact that the coil and sealing element are easy to replace.

Extras:

- normally open
- manual operation
- temperature design
- NPT thread
- limit switch
- closing muting
- increased pressure range
- explosion proof
- special voltage
- open-air assembly
- ex-limit switch
- certificate APZ 3.1, WAZ 2.2 and others
- free of oil and grease
- basic quantity setting
- deviating media and viscosities
- special flange ANSI, groove/spring
- free of nonferrous heavy metal

Force pilot operated solenoid valves

Force pilot operated solenoid valves can be used reliably both in the low pressure range from 0 bar and also for higher pressures. We have designed special valves using this control method, operating with zero differential pressure. To avoid water hammer effects, an adjustable close muting is fitted as standard in versions from size DN 32 upwards.



Application fields

- Filling systems
- Steam boiler construction
- Liquid gas systems
- Hot water applications
- Heating circuits
- Power plant technology
- Petrochemicals
- Pump equipment
- Tank systems
- Water treatment
- Pipeline construction
- Drinking water supplies
- and many other applications in the general machine and equipment construction field

Body and sealing materials

- Body made of brass, stainless steel, GG-25, GS-C25
- Seals made of NBR, EPDM, FKM, PTFE
- Peek for high temperatures and pressures

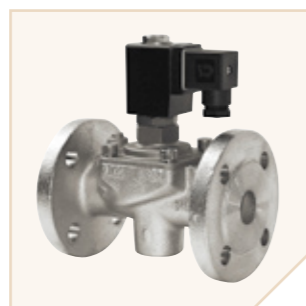

Type 27



Type 43



Type 49



Type 49K/TH



Type E24TH/K24/24



Type G24/T24



Type 1/041*



Type 2/164*

Type	Design	Nominal size	Connection		Function	Pressure range min/max	Medium	Medium temp.		Elect. Connection
			Threaded	Flanged				norm. °C	max. °C	
43	2/2-Way valve with diaphragm seal	DN13 - DN50	G ¹ / ₄ -G2		NC/NO	0-16 bar		-10/+80	-20/+130	12*, 24*, 48*, 110, 120*, 230, 240*V DC/AC EEx (e) m II T4 Encapsulation „m“ Cable or terminal connection Voltage tolerance +5/-10% EEx ia II c intrinsically safe
27	2/2-Way valve with diaphragm seal	DN15 - DN200		PN 16 PN 25/40	NC/NO	0-16 bar		-10/+80	-20/+130	
49	2/2-Way valve with piston seal	DN13 - DN76	G ¹ / ₄ -G2 ¹ / ₂ G2 ¹ / ₂ -G3		NC/NO	0-25/40 bar 0-10 bar		-10/+80	-40/+200	
49 TH	2/2-Way valve with piston seal	DN13 - DN50	G ¹ / ₄ -G2		NC/NO	0-40 bar		-40/+180	-40/+200	
49 K	2/2-Way valve with piston seal	DN13 - DN50	weld-on ends		NC/NO	0-25 bar		-40/+80		
24	2/2-Way valve with piston seal	DN15 - DN300		PN 16/40	NC/NO	0-16/40 bar	gaseous, liquid, clean	-10/+80	-40/+130	
K 24	2/2-Way valve with piston seal	DN15 - DN100		PN 40	NC/NO	0-25 bar	Viscosity up to 22 mm ² /s	-40/+80		
E 24-TH	2/2-Way valve with piston seal	DN15 - DN200		PN 16/40	NC/NO	0-16/40 bar		-40/+180	-40/+200	
G 24-TRB	2/2-Way valve with piston seal	DN15 - DN100		PN 40	NC	0-25 bar		-20/+50		
T 24-TRB	2/2-Way valve with piston seal	DN15 - DN50		PN 40	NC	0-25 bar		+180	+200	
1/041	2/2-Way valve with piston seal	DN15 - DN100	G ¹ / ₄ -G2	*	NC/NO	0-100 bar		-10/+80	-40/+180	
2/164	2/2-Way valve with piston seal	DN13 - DN100	G ¹ / ₄ -G2	*	NC/NO	0-25 bar		-10/+300	-40/+180	

* available with threaded and flange connections

Benefits of this construction design

- Wide application field, ranging from vacuum to high-pressure applications.
- Operating security of the highest order, large range of extras and combinations available.
- Acceptance inspection certificates in accordance with customer requirements APZ 3.1, WAZ 2.2, batch certificate, requirement ADMkbl., TRB 801, TRD 110 and TRbF.

Extras:

- normally open
- ex-limit switch
- NPT thread
- free of oil and grease
- free of nonferrous heavy metal
- rapid closing
- increased pressure range
- manual operation
- special voltage
- open-air assembly
- close muting
- certificate APZ 3.1, WAZ 2.2 and others
- limit switch
- explosion proof
- temperature design up to +300° C
- deviating media and viscosities
- special flange ANSI, groove/spring

Direct acting solenoid valves

Direct acting solenoid valves switch on at 0 bar up to the maximum operating pressure. The function depends on these three factors:

- Diameter of orifice
- Operating pressure
- Solenoid power



Application fields

- Low pressure gas supply for industrial and domestic applications in accordance with DIN-EN 161
- Safety control units for burner control systems
- Venting of gas and tank systems
- Vacuum technology
- Pneumatics, types 52 and 72

Body and sealing materials

- Body made of brass, stainless steel, GG-25, GGG-40.3, GS-C25
- Seals made of NBR, EPDM, FKM, PTFE

Information about PTFE seat seals for directly acting solenoid valves:

PTFE is a hard plastic and can lead to slight leaks in low pressure ranges which is why we can only certify the leak rate DIN 3230 T3 here.



Type 48*



Type 23*



Type 52



Type 53*



Type 72



Type 73



Type 75



Type 3/045

Type	Design	Nominal size	Connection		Function	Pressure range min/max	Medium	Medium temp.		Elect. Connection
			Threaded	Flanged				norm. °C	max. °C	
48*	2/2-Way valve with piston design	DN8 - DN75	G ³ / ₈ -G3		NC/NO	0-3 bar	gaseous, liquid, clean Viscosity up to 22 mm ² /s	-10/+80	-40/+130	12*, 24*, 48*, 110, 120*, 230, 240*V DC/AC EEx (e) m II T4 Encapsulation „m” Cable or terminal connection Voltage tolerance +5/-10% EEx ia II c intrinsically safe
23*	2/2-Way valve with piston design	DN15 - DN250		PN 16	NC/NO	0-1 bar		-10/+80	-40/+180	
23/48* DVGW	2/2-Way valve with piston design	DN15 - DN200	G ¹ / ₄ -G2		NC/NO	0-0,3 bar		-20/+60		
52	2/2-Way valve with poppet design	DN1 - DN6	G ¹ / ₈ -G ¹ / ₂		NC/NO	0-300 bar		-10/+80	-40/+130	
53*	2/2-Way valve with poppet design	DN4 - DN12	G ¹ / ₄ -G ¹ / ₂		NC	0-4,3 bar		-15/+60		
72	3/2-Way valve with poppet design	DN1	G ¹ / ₈ -G ¹ / ₂		Universal NC/NO	0-90 bar		-10/+80	-40/+130	
73	3/2-Way valve with piston design	DN6 - DN40	G ¹ / ₄ -G2		Universal	0-20 bar		-10/+80	-40/+180	
75	3/2-Way valve with poppet design	DN1 - DN6	G ¹ / ₄ -G ¹ / ₂		Universal NC/NO	0-40 bar		-10/+80	-40/+180	
3/045	3/2-Way valve with piston design	DN10 - DN22	G ¹ / ₄ -G1		Universal	0-250 bar		-10/+80	-20/+130	

*DIN EN 161 (DVGW)

Benefits of this design

- As this design does not have any pilot holes, the valve is less sensitive to any slight pollution of the media; except for type 73.
- Optimum use for vacuum applications.
- Highly leak-proof.

Extras:

- normally open
- ex-limit switch
- NPT thread
- free of oil and grease
- free of nonferrous heavy metal
- certificate APZ 3.1, WAZ 2.2 and others
- increased pressure range
- manual operation
- special voltage
- open-air assembly
- special flange ANSI, groove/spring
- limit switch
- explosion proof
- temperature version up to +200°
- deviating media and viscosities

Externally (pressure) controlled valves

Pressure controlled valves are suitable for controlling gaseous, high-viscose, partially polluted and also aggressive media. The actuator compartment is separated from the operating medium.



Application fields

- Filling systems
- Brewing equipment
- Chemical systems
- Mixing systems
- Food processing
- Concrete and cement industry
- Vacuum equipment
- Water treatment
- Pneumatics

Please note the following:

In the case of direct acting/externally controlled valves, massive water hammers can occur during closing when liquids flow through at high speed in the closing direction.

For this reason, we recommend a closing direction against the medium flow. The operating pressure range is limited due to the direct acting control type and the actuator size.

Type 60

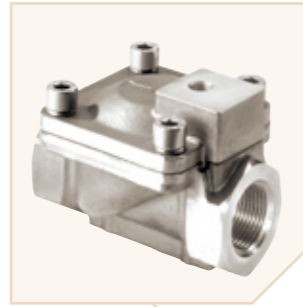

Type 63*



Type 22**



Type 26

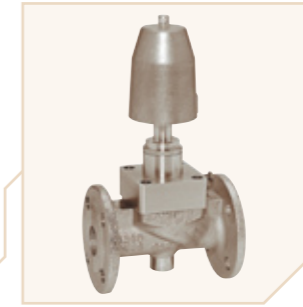

Type 79



Type 78



Type 1/921



Type	Design	Nominal size	Connection		Function	Pressure range min/max	Medium	Medium temp.	
			Threaded	Flanged				norm. °C	max. °C
60	2/2-Way valve with diaphragm seal or piston seal	DN13 - DN50	G $\frac{1}{4}$ -G2		NC	1-40 bar (0,5-20 bar)	gaseous, liquid, clean Viscosity up to 600 mm ² /s	-10/+80	-40/+200
63*	2/2-Way valve with poppet design	DN10 - DN76	G $\frac{3}{8}$ -G3		NC/NO	0-40 bar		-10/+80	-40/+200
22**	2/2-Way valve with poppet design	DN15 - DN200		PN 16/40	NC/NO	0-40 bar		-10/+80	-40/+200
26	2/2-Way valve with piston seal	DN15 - DN300		PN 16/40	NC/NO	0-40 bar		-10/+80	-40/+200
78	3/2-Way valve with poppet design	DN13 - DN50	G $\frac{1}{2}$ -G2		Universal	0-16 bar		-10/+80	-40/+200
79	3/2-Way valve with poppet design	DN15 - DN150		PN 16/40	Universal	0-16 bar		-10/+80	-40/+200
1/921	3/2-Way valve with poppet design	DN10 - DN22	G $\frac{1}{4}$ -G1		Universal	0-450 bar		-10/+80	

* available with positioner

** available with DIN EN 161 certificate

Extras:

- visual settings display
- manual operation
- free of nonferrous heavy metal
- temperatures up to +300° C
- electrical settings display
- free of oil and grease
- double-acting actuator
- NO by spring power
- vacuum-pressure design
- vacuum version
- bored flange in accordance with ANSI 150/300 lbf RF
- certificate APZ 3.1, WAZ 2.2 and others

Requirements made of the controlling medium compressed air:

filtered, free of condensate, free of dust and oil, air quality in accordance with ISO 8573.1, 4 to 10 bar

Benefits of externally controlled valves

- Simple and sturdy design for all media up to a viscosity of 600 mm²/s
- Design-related chemical and thermal resistance
- Suitable for particulate laden media
- Economical for use in Ex areas thanks to small EEx-controlling valve, type 72

Motorised Valves



Type	Design	Nominal size	Connection	Function	Pressure range min/max	Medium	Medium temp. °C
14*	2-Way valve	DN13 - DN76	Threaded	open/close control	0-40 bar	gaseous, liquid, clean Viscosity up to 600 mm ² /s	-40/+200

Motor valves as 2-Way and 3-Way versions are used both in the system construction and mechanical engineering fields for a variety of regulating tasks.

*other design on request

Body materials

Pressure level Body materials

PN16–PN40	Brass (2.0402)
PN16	Red brass RG-5 (2.1096)
PN10	Aluminium
PN40–PN150	Stainless steel (AISI 316, AISI 304, AISI 430F)

Pressure level Body materials

PN16	GG-25; DIN EN standard GJL 250 acc. to EN1561
PN25–PN40	GSC-25; DIN EN standard GP240GH acc. to EN10213-2
PN25	GGG-40.3; DIN EN standard GJS400-15 acc. to EN1563

Sealing materials

Sealing materials Properties

NBR	Standard material for neutral, gaseous and liquid media such as compressed air, water, gases. Not suitable for fuels with high levels of aromas, aromatic and hydrocarbons containing chlorine e.g. benzene, trichloroethylene. Media-temperature range: -10° C to +80° C.
EPDM	Good resistance in hot water, steam, alkaline washing lyes, bases, acids, hydraulic liquids of the group HSC and some types of the group HSD, brake fluids, e.g. ATE-blue. Not suitable for oils and greases and for aromatic and hydrocarbons containing chlorine. Very good ozone, aging and weathering resistance. Media-temperature range: -20° C to +130° C.
FKM	Good resistance in mineral oils, fuels, greases, aromatic and hydrocarbons containing chlorine, oxygen. Not suitable for hot steam. Media-temperature range: -20° C to +150° C (only for gaseous media).
PTFE	Good resistance in nearly all media. Very good chemical resistance, resistant to solvents, highly resistant to pressure. Main application fields: steam, aggressive media, cooling technology. Low friction coefficient thanks to smooth and repellent surface. Media-temperature range: -40° C to +200° C.
Peek	Can be used in pressure ranges up to 350 bar and temperatures up to +350° C.

GSR-MK-JM-PÜe-03-2008 / © GSR Ventiltechnik GmbH & Co. KG, Wöhr

Product overview

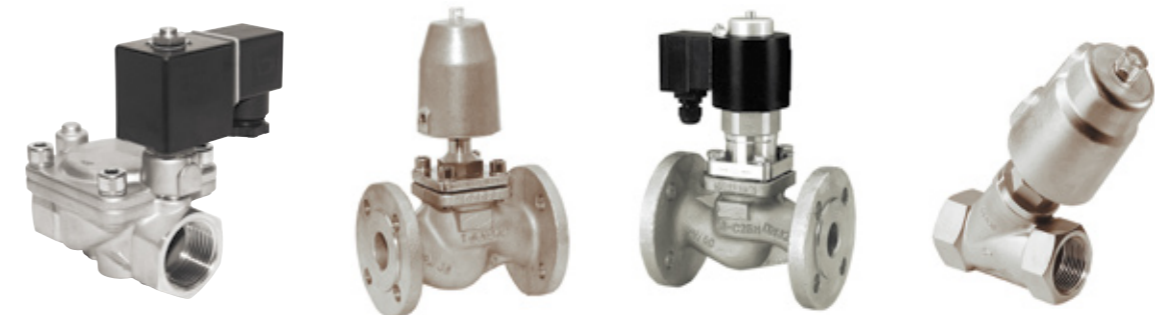

TECMA SERVICE S.r.l.
Corso Racconigi, 212
10141 TORINO

www.tecmaservice.it



printed in Germany

Innovative Valve Technology